

EASYCOOL 易酷®

PRIDE Leading New Cryogenics Technologies

KDC6000V Helium Compressor Operating Manual

 **CSIC PRIDE (NANJING) CRYOGENIC TECHNOLOGY CO.,LTD.**

REV 1.1

CATALOGUE

SAFETY

SERVICE

INTRODUCTION

PRINCIPLES of OPERATION

DESCRIPTION

SPECIFICATIONS

INSTALLATION

OPERATION

APPENDIX

(This page is intentionally blank.)

SAFETY

GENERAL

CSIC Pride(Nanjing) Cryogenic Technology Co.,Ltd. (CPCT) equipment is designed to operate safely when the installation, operation and servicing are performed in accordance with the instructions in this technical manual. For Service Center locations, see the Service section of this manual.

SPECIAL NOTICES

Three types of special notices -- WARNINGS, CAUTIONS and NOTES are used in this technical manual.

WARNINGS

WARNINGS call attention to actions or conditions that can result in serious injury or death.

CAUTIONS

CAUTIONS call attention to actions or conditions that can result in damage to the equipment or in abnormal performance.

NOTES

NOTES give important, additional information, explanations or recommendations related to the appropriate topic or procedure.

Like other safety instructions, appear within rectangles in the text where they are applicable. Because of their importance, they are summarized in this Safety section and in the General Technical Manual, and should be read first.

WARNINGS!

AVOID ELECTRIC SHOCK.

All electrical supply equipment must meet applicable codes and be installed by qualified personnel.

Disconnect the power to the compressor before troubleshooting the electrical components.

Permit only qualified electrical technicians to open electrical enclosures, to perform electrical checks or to perform tests with the power supply connected and wiring exposed. Failure to observe this warning can result in serious injury or death.

AVOID INJURY.

Never use compressed helium gas from a cylinder without a proper regulator. Overpressure can cause serious injury if the system equipment ruptures.

During operation, some surfaces under the compressor's cover become hot. Allow the compressor to cool for 1/2 hour after shutdown before removing the cover for maintenance.

Always wear eye protection when handling pressurized gas lines and other pressurized equipment. Never apply heat to a pressurized gas line or other pressurized components.

Disconnect gas lines only when the compressor is stopped. Disconnecting the cold head while it is cold can create excessively high internal pressure as the gas warms. Material failure and uncontrolled pressure release can cause serious injury.

Use two wrenches when disconnecting a gas line coupling to avoid loosening the cold head or compressor coupling. Gas pressure can project the coupling with enough force to cause serious injury.

The compressor is charged with helium gas. Except when disconnecting the absorber or the gas lines, vent both supply and return Aeroquip couplings to atmospheric pressure before disassembly.

Always vent a gas-charged component before beginning to disassemble its couplings. Gas pressure can launch a loose coupling with enough force to cause serious injury.

The absorber is charged with helium gas. Follow the used absorber venting procedure for safe disposal of the used absorber.

CAUTIONS!

PRESERVE YOUR WARRANTY.

Equipment without warranty will void warranty. Modification to equipment without the consent of the manufacturer will void the warranty. Specifications require the use of 99.999% pure helium gas. Using a less quality helium can damage the system and void the warranty.

AVOID GAS LEAKS.

Check the condition of the gasket face seal. Be sure the gasket face seal is in place and the sealing surfaces are clean before connecting. Replace the gasket face seal if it is damaged or missing. Keep the gas line couplings aligned when making or breaking a coupling connection. Leaks can occur due to the weight of the gas line or due to a sharp bend near the connection.

AVOID CONTAMINATION.

When you want to check the compressor for shipping damage, please do not connect the gas lines and the cold head. The components may become contaminated with compressor oil. Follow the charging or venting procedures to prevent reversed flow of system gas. Do not charge through the supply coupling. Do not vent through the return coupling. Reversed flow can contaminate the system with compressor oil. A leaking coupling on an Absorber should not be repaired in the field. Consult a Service Center. Venting the Absorber will introduce contaminants to the system, which cannot be removed in the field.

PREVENT EQUIPMENT DAMAGE.

Damage to gas lines can result from crimping by repeated bending and repositioning. Drain cooling water from the compressor unit prior to transportation or long downtime. If the compressor is wired for 380/400 ($\pm 10\%$) V3~ electrical service, connecting to a higher voltage may damage the control circuit. Similarly, if it is wired for 480 ($\pm 10\%$) V3~, 60 Hz, it can be damaged by connected to 380/400 V3~. Never pull a vacuum on the compressor or on the cold head. The motors will short circuit if started. After starting the system for the first time, make sure that the water lines are properly connected, check that the outlet water temperature is warmer than the inlet water.

For an installation using a water chiller or other circulating cooling system.

Use pure ethylene glycol with water for the coolant antifreeze solution. Do not use commercial ethylene glycol sold for automotive cooling systems, which usually contains a fine grit material that can damage the cooling system. Please strictly refer the water quality requirements in the manual, special the chlorine content, excess may cause the heat exchange to be corroded.

AVOID A MALFUNCTION.

Repeatedly charging the system with helium gas rather than locating and repairing gas leaks can cause a malfunction. Impurities are introduced at an abnormal rate and can freeze in the cold head. Air is not allowed to get into the helium gas refrigerant of the system. Moisture from the atmosphere can seriously degrade cold head performance.

AVOID EQUIPMENT FAILURE, CONTAMINATION OR A NUISANCE SHUTDOWN.

Do not tip the compressor greater than 5 degrees from horizontal, to avoid flowing oil into unwanted places.

SERVICE

SERVICE CENTER

Address: No.32 Changqing Street, Jiangning Development
District, Nanjing 211106, China

TEL: +86-25-68626268

FAX: +86-25-68626273

E-MAIL: cryosales@724pride.com

INTRODUCTION

Helium Compressors, Model KDC6000V

The compressors are designed to deliver high-pressure, oil-free, helium gas to cryogenic refrigerators. Cold head cables are used with the compressor to supply electrical power to cold heads. Self-sealing gas couplings allow for easy connection to and disconnection from the rest of the closed-cycle cryogenic refrigeration system.

Pressures are stated as gauge pressure, not absolute pressure. The units are bar and pounds per square inch (psig). For reference:

1 bar = 14.5 psi.

1 MPa = 10 bar

Definition of Symbols used in this manual and on equipment:



Symbols	Definitions
	Mains Disconnect On
○	Mains Disconnect Off
	Note
	Protective Earth (Ground)
	Dangerous Voltage
V3~	Volts, AC, 3 phase

Figure 1 Symbols and Definitions

PRINCIPLES of OPERATION

The compressor continuously draws low-pressure helium from the system return line. It compresses, cools and cleans the gas, then delivers it through the system gas supply line to the cold head. See Figure 2.

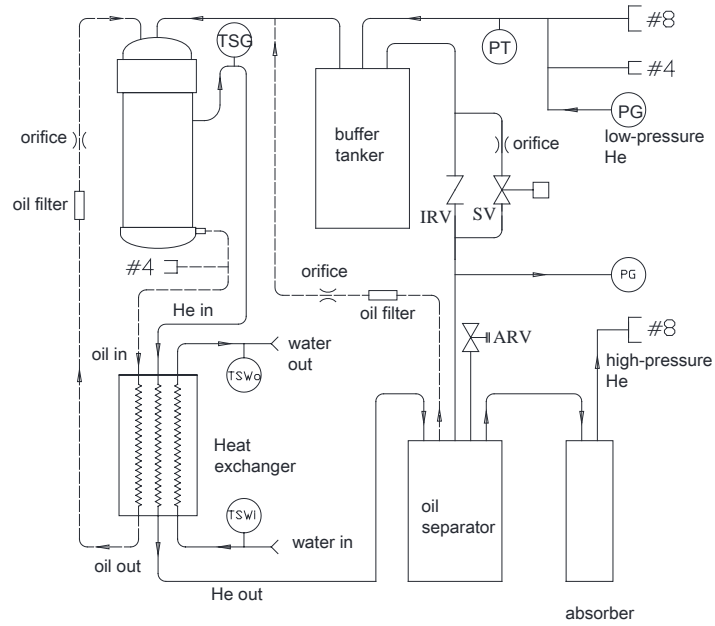

Figure 2 Compressor Flow Diagram

Key

Acronyms	Explanations
TSG	Gas temperature thermistor
TSWi	Water-in temperature thermistor
TSWo	Water-out temperature thermistor
ARV	Atmospheric relief valve
IRV	Internal relief valve
SV	Solenoid valve
PT	Pressure transducer
PG	Pressure gauge

When helium gas leaves the compressor capsule, the gas contains heat and compressor lubricant. Both must be removed. From the compressor capsule, the hot gas with its entrained oil flows out of the shell. The gas then flows through one circuit of a three-circuit, water cooled, heat exchanger, where it is cooled. Next, the gas passes through the oil separator and the Absorber for oil and moisture removal. From the Absorber, the high-pressure helium gas flows to the cold head through the gas lines.

Through the system gas return line, low-pressure gas from the cold head flows into the compressor. A gas line containing an internal relief valve (IRV) connects the high-pressure line to the low-pressure line. The relief valve will open to prevent overloading the motor when the system gas lines are not connected to the compressor.

Oil is separated from the gas in three stages. The first stage is by gravity when the gas passes through the first stage oil separator. The second stage is in the second oil separator whose element collects oil mist from the gas; oil is agglomerated and returned to the compressor. The third stage is the Absorber that removes any remaining oil the gas is carrying.

Oil collected in the oil separators flows back to the compressor capsule through capillary tubes and orifices. The differential gas pressure across the system is the moving force, and the restriction size limits the amount of gas bypassed. The small amount of oil collected in the Absorber remains there and can be removed by replacing the Absorber.

Before returning to the compressor capsule, the oil separated in the first stage oil separator flows through the heat exchanger where it is cooled. It is then injected into the low pressure side of the compressor capsule to absorb heat and lubricate the compressor capsule.

DISCRIPTION

Components

Helium Supply and Helium Return Pressure Couplings

Both supply (high pressure) and return (low pressure) are self-sealing, size 8, male (8M), Aeroquip, bulkhead couplings and are the points of connection on the front panel for the gas lines.

Helium Charge

A size 4, male (4M), Aeroquip coupling located on the front of the compressor is used for charging or venting helium gas refrigerant.

Water In and Out Fittings

KDC6000V is fitted with two (2) ½" MNPT.

Pressure Gauge

Indicates gas pressure in the supply line and gas return line. When the compressor is not running, the two (2) gauges located on the compressor's front panel shows the equalization pressure.

Cold Head Power Receptacle

Mounted on the front panel for connecting a cable to supply electrical power from the compressor to the cold head.

Mains Power Switch

Mounted on the front panel, it creates a way to disconnect power and it protects the compressor from electrical overload. This device is labeled by "Main Power" .

Fuses

Three (3) (380/550V-GB13539) fuses, located inside the electrical chassis box, protect the overload of input circuit and transformer. Three (3) (0.8A/250V) fuses, located on the circuit, supply and protect cold head motor. 24V circuit uses resettable fuses (AHEF100/1A) to protect the circuit board.

Electrical Chassis

The electrical box contains electrical components and connections and distributes power to all system circuits.

Heat Exchanger

Using water to cool the high-pressure helium refrigerant and the compressor's lubricating oil.

Oil Separator

Removes most of the remaining entrained oil from the gas stream. This unit needs no servicing or replacement.

Oil Orifice

The orifice returns oil collected in the oil separator sump to the compressor for recycling.

Absorber

The absorber removes any oil and moisture the gas is carrying which did not drop out in the separator. The absorber has a finite life and must be replaced at regular intervals.

Atmosphere Relief Valve [ARV]

The pressure relief valve prevents the compressor from operating at an unsafe pressure by venting to the atmosphere.

Oil Filter

Filters in the oil lines ensure that the oil returns to the capillary and orifices is clean, and won't block the capillary and orifices.

Water High Temperature Thermistors

Sense water temperature. One each is located in the "water in" line and in the "water out" line. They provide a warning if the inlet or the outlet water temperature is too high. High outlet water temperature indicates low water flow.

Compressor High Temperature Motor Protector Switch

Located inside the compressor motor, the switch senses compressor motor temperature and stops the motor if the temperature is too high. The switch resets after cool down.

Supply Gas High Temperature Thermistor

Senses discharge gas temperature. It causes the compressor to shut down if the temperature of the high-pressure helium from the compressor is too high.

Oil Injection Orifices

These orifices are installed in the oil return lines and control the flow rate of oil returned to the compressor.

Internal Relief Valve [IRV]

The internal relief valve opens to allow the compressor to be operated in the stand-alone mode or when the system gas lines are disconnected, to avoid overloading the motor.

SPECIFICATIONS

KDC6000V Compressor Details

Two (2) size 8M gas couplings; water-cooled; 380/400V ($\pm 10\%$) V3~, 50 Hz or 480V ($\pm 10\%$) V3~, 60 Hz.

Electrical Characteristics

Service required: Delta connected, 4 wires (3 phase plus protective ground or earth.) A screw-mounted, detachable connector is provided on the electrical front panel for connecting power to the compressor.

KDC6000V Transformer Voltage Tap Selection: The proper transformer voltage tap must be selected to match the incoming supply voltage. If not, open the transparent cover on the front panel, select the right input voltage. The default value is 380V, and 380/400V and 480V can be chosen.

Power consumption Gifford-McMahon (GM) Operation	Startup
KDC6000V	< 8.5 kW@50Hz
	< 9.0 kW@60Hz

Rated load current:

For the KDC6000V compressor, 13 amperes

Locked rotor current:

For the KDC6000V compressor, 75 amperes at 60Hz, 67-74 amperes at 50Hz

Internal circuit protection

Transformer:

Three (3) (BUSSMAN FNQ-R-2) fuses, located inside the electrical chassis box, protect the overload of input circuit and transformer.

Cold head motor:

Three (3) (littlefuse 250V/0.8A) fuses, located on the circuit, supply and protect cold head motor.

Control circuit:

Uses resettable fuses (AHEF100/1A) to protect the circuit board.

Fuses are located inside the electrical chassis box, for service by qualified electrical technicians only.

Cold head power requirement:

200 V3~, 0.53 amperes, supplied from the compressor.

Cold head power supply:

A cable connects the cold head to the compressor.

Class I:

Grounded equipment

Compressor control logic provides:

- ON and OFF buttons for operation of the compressor and the cold head.
- Front panel LCD display of operating time.
- Push “DISPLAY” button to scroll the LCD display.
- Interlock to prevent starting the compressor and the cold head if the main power phase sequence is incorrect.
- Automatic restart of compressor after power interruption.

Automatic shut off for the following system faults. Operator correction is required before press the “RESET” button.

- High gas discharge temperature, when thermistor reads > 93° C (5 automatic restarts at 20 minute intervals before operator correction required).
 - High compressor motor windings temperature, switch opens at 160° C, resets at 69° C.
 - High compressor motor current draw: KDC6000V trips at 16 amperes.
 - High cold head motor winding current, high solenoid valve motor current, open fuse(s).
 - Low gas return pressure, < 1.3bar
- Error warning displayed for the following system faults, no automatic shutoff:
 - High water temperature, > 38° C
 - Low water flow, high water out temperature, > 46° C

See the Compressor Wiring Diagrams

Front Panel Connections (See Figure 3)

- Helium gas connections: size 8, male (8M) Aeroquip couplings, high-pressure supply and low-pressure return.
- Helium fill port: size 4, male (4M) Aeroquip coupling.
- Cooling water connections: Swagelok bulkhead fittings, ½” MNPT.
- Mains power connector: Rectangular industrial connector
- Diagnostic interface connector: DB-25, for control and to indicate error condition. (See appendix)
- Definitions of Diagnostic Interface Connector of this manual)

Front Panel Mounted Items (See Figure 3)

- Supply pressure gauge (0-40 bar, 0-600 psi)
- Return pressure gauge (0-40 bar, 0-600 psi)
- LCD display (to display compressor status)
- ON and OFF buttons
- DISPLAY buttons (to scroll the LCD display)
- RESET button (to reset errors)
- Main power switch
- Voltage selection access panel

Environmental Requirements

Item	Operating	Storage
Ambient Temperature	4-40°C	-20-65°C
Relative Humidity	30%—70%	10%-90% (non-condensing)
Magnetic Field Limits	≤50 Gauss	
Atmospheric Pressure	70kPa-110kPa	20kPa-110kPa

NOTES

Operating the equipment out of specifications may void the warranty.

Mounting Position

Compressor must be mounted base down and level within 5 degrees of horizontal.

Cooling Requirements

Application	Cooling water flow rate
4K GM and 10K GM Cold Head	6-9L/min
Cooling water inlet temperature	5° C to 25° C
Cooling water outlet temperature	46° C maximum
Cooling water supply pressure	8 bar (116 psig) maximum
Pressure drop at 9 L/min	<1 bar (<14.5 psi)
Alternative coolant	50% pure ethylene glycol + 50% water
Ethylene glycol/water (50/50) flow rate	7.8 to 11.7 L/min

CAUTION!

For an installation using a water chiller or other circulating cooling system.

Use pure ethylene glycol with water for the coolant antifreeze solution. Do not use commercial ethylene glycol sold for automotive cooling systems, which usually contains a fine grit material that can damage the cooling system.

Water Quality Requirements

Water supplied for cooling the compressor should be filtered through a 300-micron screen and meet the following quality limits:

Item	Initial Values for non-Replenished (closed) System	Values for Continuously Replenished (open) System
Suspended solids, µg/L	<250	<250
Particle size, µm	<300	<300
pH (25°C)	6.5-8.0	6.0-8.0
Alkalinity (ppm)	100 max.	50 max.
Hardness (ppm)	200 max.	50 max.
Chloride (ppm)	200 max.	50 max.
Sulfate (ppm)	200 max.	50 max.
Iron (ppm)	1.0 max.	0.30 max.
Sulfur ion (ppm)	None detected	None detected
Ammonium ion (ppm)	1.0 max.	0.20 max.
Silica (ppm)	50 max.	30 max.

CAUTION!

FOR AN INSTALLATION USING A WATER CHILLER OR OTHER CIRCULATING COOLING SYSTEM.

Please strictly refer the water quality requirements in the manual, special the chlorine content, excess may cause the heat exchange to be corroded.

Helium Gas Pressures

Equalization Pressure at 20°C for 12 to 20 m long gas lines ¹	Operating (Supply) Pressure ²	Operating (Return) Pressure ²
16-16.5 bar (16.1 bar nominal)	20-23 bar (290-334 psi)	2.8-6.9 bar (40-125 psi)

1 Under equalization pressure, the readings of high pressure gauge and low pressure gauge may be different because of error of pressure gauges. It is suggested to take high pressure gauge as preliminary preference.

2 The supply and return pressure vary according to the heat load of cold head and ambient temperature.

Refrigerant Quality

Refrigerant is 99.999% pure helium gas with a dew point temperature less than -50°C at 20.7 bar.

CAUTION!

PRESERVE YOUR WARRANTY.

Specifications require the use of 99.999% pure helium gas. Using a lesser quality of helium can damage the system and void the warranty.

Color Codes

SUPPLY (yellow) - Helium high-pressure gas supply from the compressor to the cold head.

RETURN (green) - Helium low-pressure gas return to the compressor from the cold head.

Optional Spacing

Allow 600 mm space in front of the compressor for access to electrical, water and gas connections. Allow 600 mm space on the left side (when facing the front) of the compressor for maintenance of the absorber.

Maintenance Intervals

Compressor absorber: 36 months.

Noise Level

$< 70\text{ dB(A)}$ at 1m

Dimensions

See Figure 4. Three removable eyebolts are furnished for lifting.

Weight (approximate)

Compressor: 107 kg

General Operating Conditions

Normal pressure and temperature data are listed above. User should record monthly the operating conditions in a logbook. Keep this record of data for reference and later comparisons.

Supplier Name and Address

CSIC Pride(Nanjing) Cryogenic Technology Co.,Ltd.
No.32 Changqing Street, Jiangning District, Nanjing 211106 P.R.C.
TEL: +86-25-68626268

Application of Q/320115 NJKD01-2011 Standard

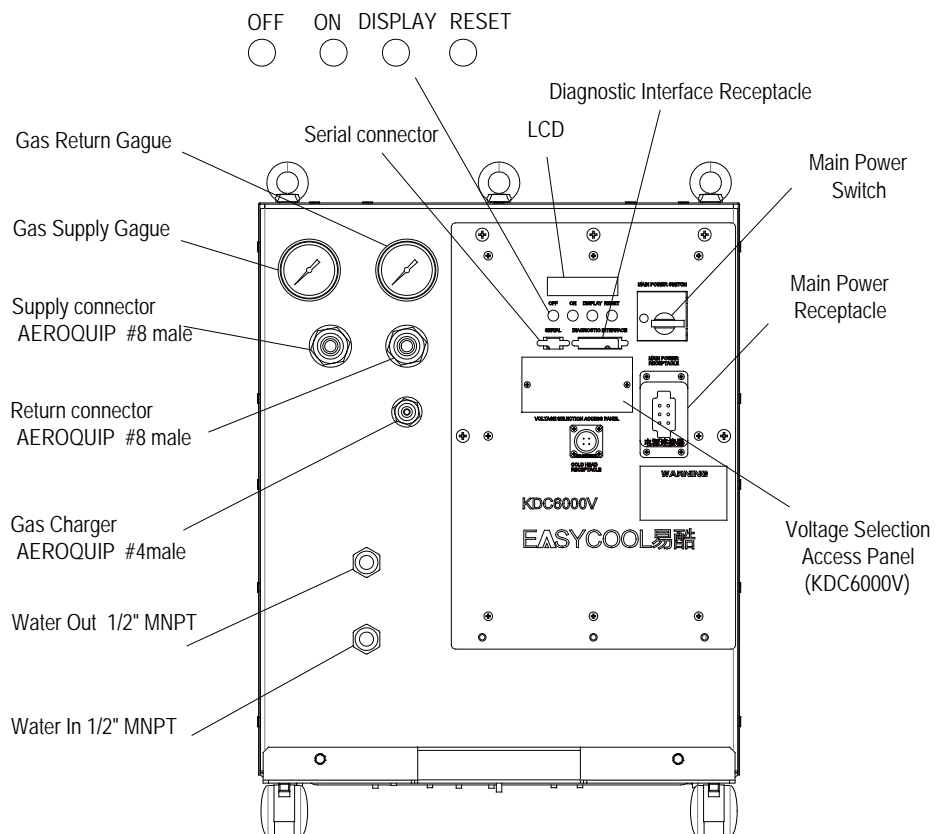

Figure 3 KDC6000V Compressor, Front View

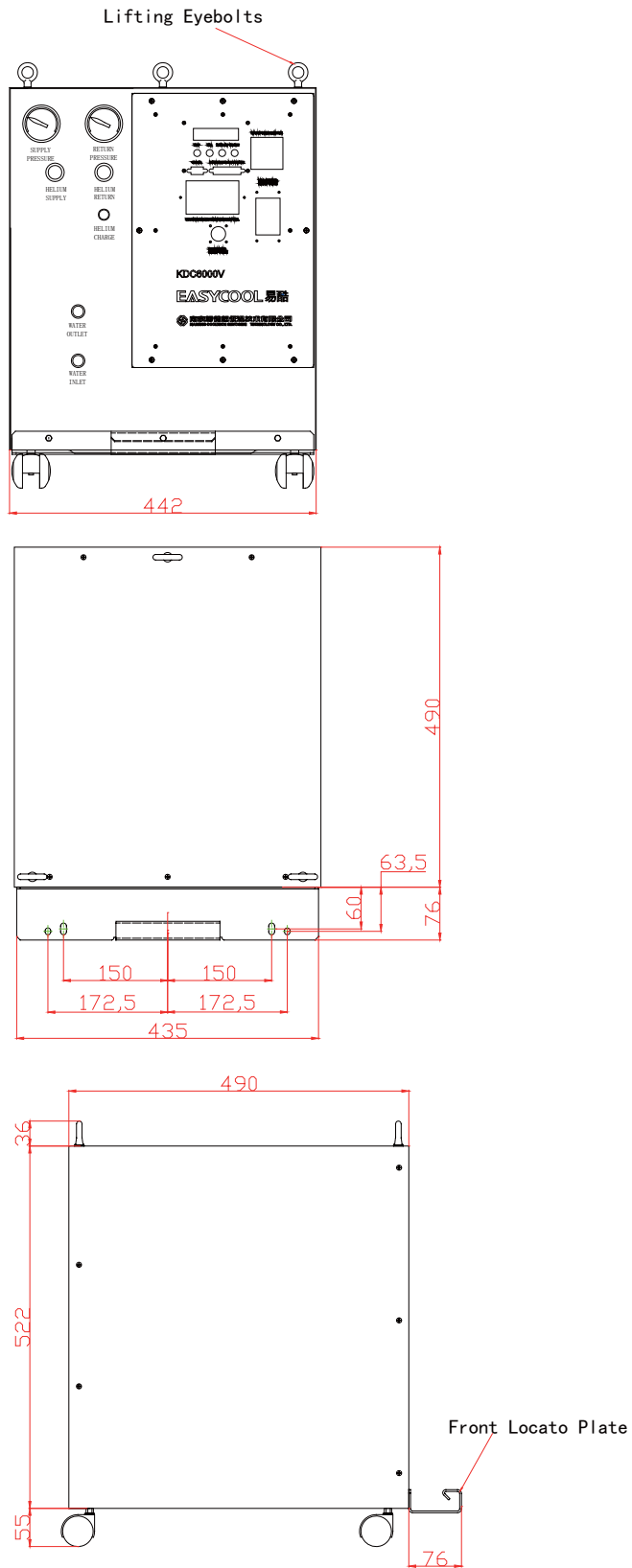

Figure 4
KDC6000V Compressor, Dimensions (mm)

INSTALLATION

Introduction

Install the KDC6000V Compressor, Cold Head Cable and the Gas Lines according to the following procedures. The following installation procedures are based on standard arrangements of equipment, using CPCT standard components.

To prevent contaminating the components or the system, it is important to follow the procedures in this manual step by step.

NOTE

Be sure to have 99.999% pure helium gas available for installation of the system.
See Refrigerant Quality in Specifications.

Receipt Inspection Instructions

CAUTION!

AVOID EQUIPMENT FAILURE, CONTAMINATION OR A NUISANCE SHUTDOWN.

Do not tip the compressor more than 5 degrees from horizontal to avoid flowing oil into unwanted places.

CAUTION!

AVOID CONTAMINATION.

When checking the compressor for shipping damage, do not connect gas lines and cold head. The components may become contaminated with compressor oil.

- 1、 Upon receipt, inspect the shipping container and the compressor for damage.
 - 1.1 If there is any evidence of external damage to the container, be sure the carrier's driver sees the damage. Note it on the shipping documents and have the driver acknowledge it by his initials on the delivery receipt.
 - 1.2 Remove the compressor from its shipping container and inspect for damage. If there was external damage to the compressor, remove its covers and check for internal damage. Notify the carrier immediately and take photographs of the damage to document your claim to the carrier. Keep the damaged shipping container.

NOTE

Retain the shipping containers, if reusable, for returning the components to the factory if reconditioning is required. If internal damage is suspected, retain the shipping container for proof to the carrier.

2、 Inspect for Proper Charge Pressure

The pressure gauge on the front panel of the compressor should indicate 16-16.5 bar (232 - 239 psi) at 20° C. If the gauge indicates 0 psig (0 bar), the Compressor Unit cannot be used. Contact the supplier.

3、 Upon receipt, inspect Tip-N-Tell Sensor on Package for Activation

3.1 The Tip-N-Tell sensor mounted on the shipping container package surface should be checked upon receipt and before unpackaged to verify the “Compressor Unit shipping container” was NOT tipped during transport.

3.2 If activated, Tip-N-Tell sensor won't turn red in the arrow as shown below. Proceed with internal inspection. If the sensor turns red, notify the carrier immediately and take photographs of the tip to document your claim to the carrier.



2. Inspect the Tip-N-Tell Sensor on Compressor Unit for Activation.

2.1 Check the Tip-N-Tell sensor mounted on the compressor rear panel. If the Tip-N-Tell sensor shows no mishandling and there is no apparent physical damage, skip Steps 2.2 and 2.3 and proceed to the section Compressor Location.

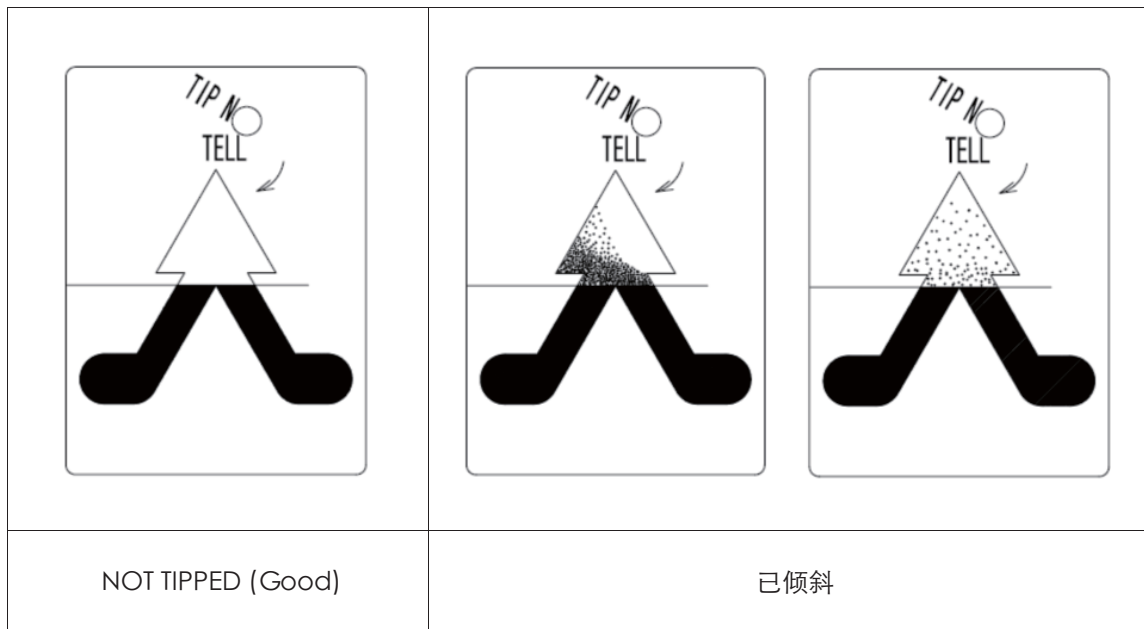

2.2 The equalization pressure is within specifications:

If the compressor has been momentarily tipped (less than one hour) and the equalization pressure is within specifications, allow it to stand upright for two hours before performing this step.

Connect power and water to the compressor. See the next sections Compressor Location, Electrical Supply Connection, Coolant Connections. Test run the compressor for two (2) hours minimum. If there are no problems during this time, stop the compressor and proceed to assemble the system.

If the compressor malfunctions during the two (2) hour test, contact the supplier. TEL: +86-25-68626268; FAX: +86-25-68626273.

2.3 If the equalization pressure is outside the specified range or there is physical damage to the compressor enclosure or the compressor has been on its side or upside down for an extended period of time (more than one hour), contact the supplier and notify the delivering carrier of the damage.

电话：025-68626268 传真：025-68626273

NOTE

When checking the compressor for shipping damage, do not connect gas lines and cold head. The components may become contaminated with compressor oil.

3. Inspect for Visible Damage of Compressor Unit.

- 3.1 Inspect the exterior panels of the Compressor Unit for evidence of damage.
- 3.2 If there was external damage to the compressor, remove the compressor unit panels and check for internal damage. Notify the carrier immediately and take photographs of the damage to document your claim to the carrier.
- 3.3 If any irrecoverable damage is found (e.g. oil Leakage, panel deformation), contact the supplier.

Compressor Location

Place the compressor in a location that is protected from the elements and where the ambient temperature will always be within the range of 4° C to 40° C.

The compressor must be installed base down, within 5 degrees of horizontal, and preferably at a height convenient for making connections and reading the pressure gauge.

Allow 600 mm space in front of the compressor for access to electrical, water and gas connections. Allow 600 mm on the left side (when facing the front) of the compressor for maintenance of the absorber.

Compressor Electrical Control Panel

See Figure 5.

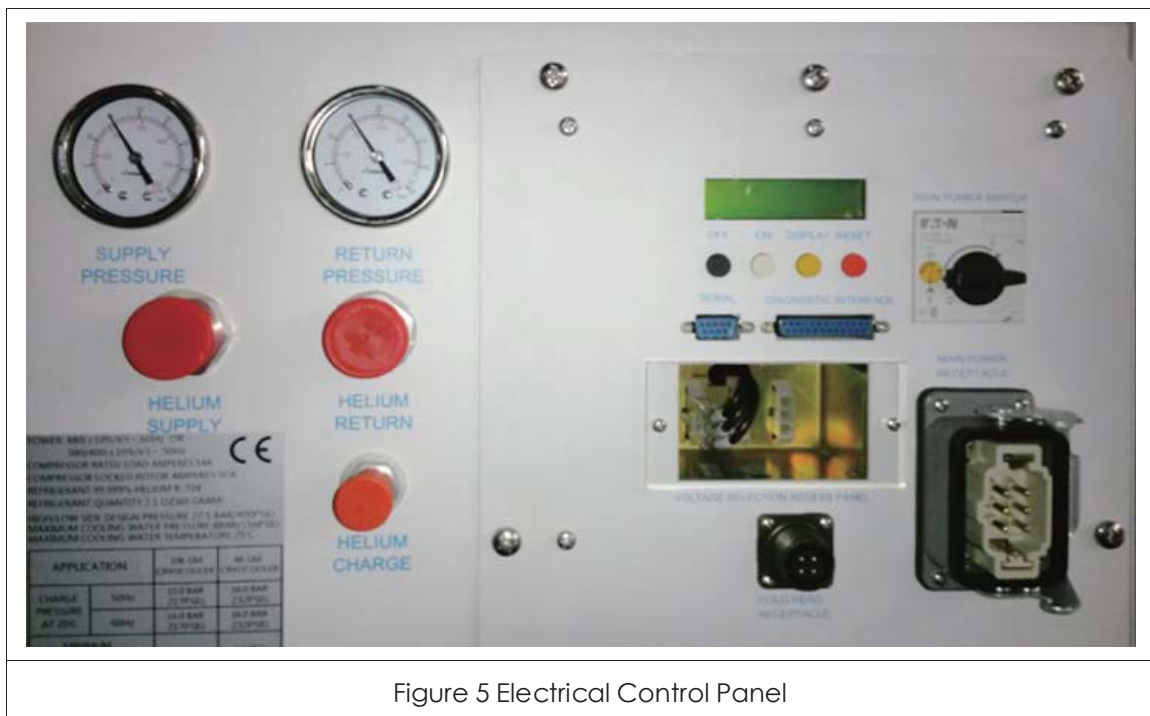

Figure 5 Electrical Control Panel

Compressor Voltage Selection

The KDC6000V Compressor is factory set for 380 V3~. L1, L2, L3, G are connected to A phase, B phase, C phase and ground respectively. After the power is connected, if the LCD displays EASYCOOL/Phase seq:Err, it means your input phase sequences are not right. Interchange any two adjacent phases.

Before power is supplied, the following procedure must be applied.

WARNING!

AVOID ELECTRIC SHOCK.

Permit only qualified electrical technicians to open electrical enclosures, to perform electrical checks or to perform tests with the power supply connected and wiring exposed. Failure to observe this warning can result in serious injury or death.

CAUTION!

PREVENT EQUIPMENT DAMAGE.

PREVENT EQUIPMENT DAMAGE. If the KDC6000V Compressor is wired for 380/400 V3~, 50 Hz electrical service, connecting it to a higher voltage may damage the control circuit. Similarly, if it is wired for 480 V3~, 60 Hz, it can be damaged by connecting to 380/400 V3~.

1. Disconnect the mains power supply to the compressor.
2. Remove the clear plastic cover at the voltage selection access panel on the front of the compressor.
3. Move the exposed connector to the voltage tap connector labeled for the correct supply voltage. For customers in Mainland China, the default input voltage is 380V (400V), 50Hz. If the voltage needs to be adjusted, qualified technicians shall read the manual thoroughly, or contact the supplier. TEL: +86-25-68626268; FAX: +86-25-68626273, see Figure 6.
4. Replace the clear plastic window.
5. Reconnect the compressor's main power.

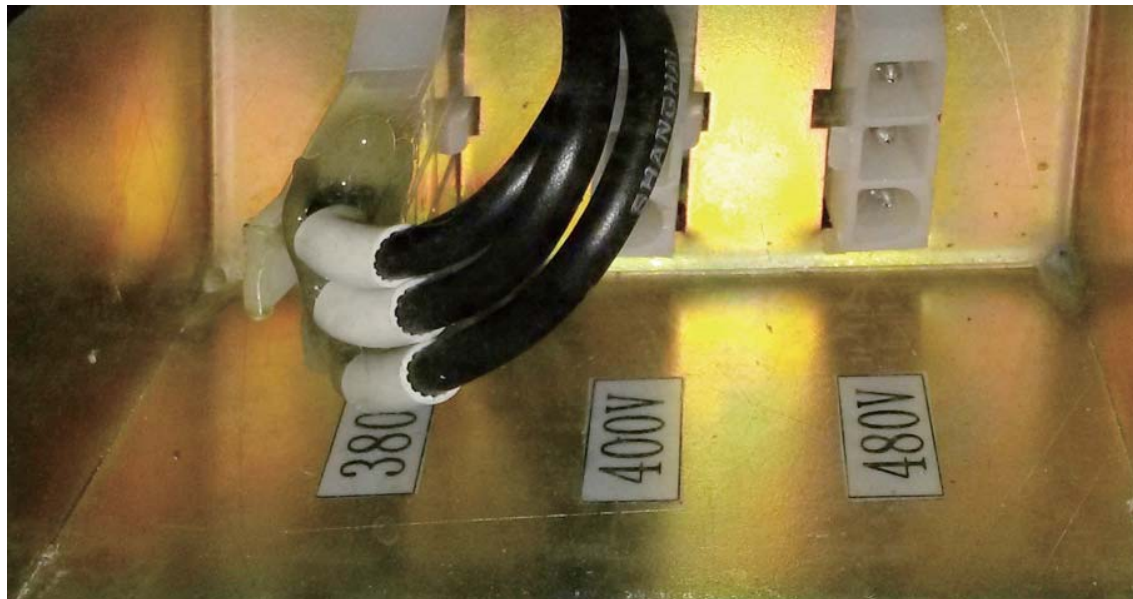

Figure 6 Voltage Selection

Supply Connection

The Compressor must be installed in a circuit capable of supplying the specified voltage and power. The wiring method used for connection to the front panel power connector must meet applicable codes. Male joint and female joint shall be matched.

⚠ WARNING!

AVOID ELECTRIC SHOCK.

All electrical supply equipment must meet applicable codes and be installed by qualified personnel. Permit only qualified electrical technicians to open electrical enclosures, to perform electrical checks or to perform tests with the power supply connected and wiring exposed. Failure to observe this warning can result in serious injury or death.

Connect mains power supply cable into the mains power receptacle (see Figure 7) on the front panel and fasten cover with attached screws. See Figure 8.



Figure 7 Mains Power Receptacle



Figure 8 Connect Mains Power Supply Cable to Mains Power Receptacle

Main Power Switch

Main power switch see Figure 9.



Figure 9 Main Power Switch

Button Control

From left to right, the buttons are OFF, ON, DISPLAY, RESET. See Figure 10.



Figure 10 Button Display

LCD Display

See Figure 11 for LCD Display.



Figure 11 LCD Display

Cold Head Motor Socket

See Figure 12 for cold head motor socket.



Figure 12 Cold Head Motor Socket

Coolant Connections

Tools required: Open-end wrench. Wrap the water in and water out thread (1/2" MNPT) on the front panel of the compressor with tapes. Using two wrenches to connect coolant supply and return lines to the water in and water out fittings on the front of the compressor. See Figure 13. Ensure that the Water In connection is connected to the supply line from the user's cooling water or coolant supply. Turn on the coolant and check the water lines for leaks. Tighten the fittings if necessary. See Specifications for cooling requirements.



Figure 13 Connect and Remove the Water Lines

CAUTION!**PREVENT EQUIPMENT DAMAGE.**

Please strictly refer the water quality requirements in the manual, special the chlorine content, excess may cause the heat exchange to be corroded.

Compressor Checkout

The compressor should be operated before being connected to the other system components.

1. For the KDC6000V Compressor, be sure that the transformer voltage taps are correctly selected to match the supply voltage.
2. Supply power to the compressor. Set the compressor's Main Power switch to on. Push the ON button. Run the compressor for ten (10) minutes and then stop.
3. While the compressor is running, lightly touch the water supply and return lines. The return (water out) line should be warmer. If the return water line is cooler than the supply (water in) line, stop the compressor and reverse the water connections.

NOTE

The compressor has reversed-phase protection to prevent it from running in reverse. If it does not start and the LCD displays "EASYCOOL/Phase Seq:ERR", disconnect the power and interchange any two mains supply wires (except ground). Refer to the Troubleshooting section in this manual.

If the compressor starts but does not build pressure, turn it off immediately. It could be running in reverse despite the above-mentioned phase monitor relay. Contact the supplier if this occurs.

This completes the checkout of the compressor.

Install the Gas Lines

Tool required: Open-end wrenches, 1", 1/8", 1 3/16"

Gas lines are shipped with protective dust plugs. Do not remove the plugs until the gas lines are ready to be attached. All bending and routing of gas lines should take place with plugs in place.

⚠ WARNING!

AVOID INJURY.

Always wear eye protection when handling pressurized gas lines and other pressurized equipment. Never apply heat to a pressurized gas line or other pressurized components.

⚠ CAUTION!

PREVENT EQUIPMENT DAMAGE.

Damage to gas lines can result from crimping by repeated bending and repositioning.

NOTE

Be sure to have 99.999% pure helium gas available at the installation site in case gas needs to be added to the system. See Refrigerant Quality in Specifications in this manual.

1. Identification labels are furnished with the gas lines. Before installing the gas lines, identify each with an appropriate label, SUPPLY (high pressure, color-coded yellow) or RETURN (low pressure, color-coded green) by applying the label adjacent to each coupling. See Figure 14.

2. Arrange the system components so that the gas lines will be protected from stress and traffic. Observe the minimum bend radius of 200 mm when routing gas lines. Provide supports where needed.



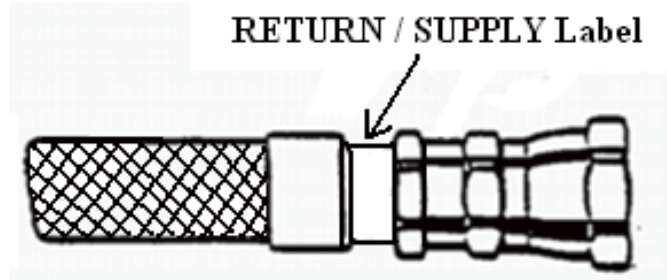

Figure 14 Attach Identification Label

NOTE

Supply and return gas lines are identical. Labels are used to prevent making a wrong connection at installation or at reassembly following maintenance.

3. Remove the dust caps from the compressor's supply and return gas couplings.

Connect the gas lines to the compressor's supply and return couplings. Use two wrenches to tighten the coupling. Torque all couplings to 47 ± 7 Nm. See Figure 15. Tighten each coupling before proceeding to the next one.

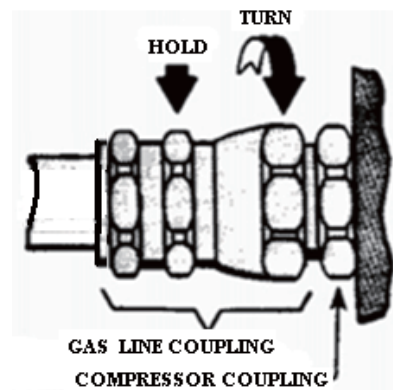

Figure 15 Gas Line Connections

⚠ CAUTION!**AVOID GAS LEAKS.**

Check the condition of the gasket seal on the female half of each coupling. Be sure the gasket seal is in place and the sealing surfaces are clean before connecting. Replace the gasket seal if it is damaged or missing. Keep the gas line couplings aligned when making or breaking a coupling connection. Leaks can occur due to the weight of the gas line or due to a sharp bend near the connection.

NOTE

Retain the dust caps and plugs to re-cover the couplings when they are not in use.

Adjust System Equalization Pressure

When the compressor is at room temperature of 20°C, check to see if its equalization pressure is at a constant value. When it is at equalization pressure, the pressure will change slightly based on the temperature change. If the pressure deviated from the specified range, check to see if the gas supply is wrong, or gas leaks.

1. Check all the gas lines connecting the compressor and cold head according to the system schematic diagram.
2. Connect power to the compressor. Switch the compressor mains power to ON. Do not start the compressor.
3. Press DISPLAY. The display on front panel reads EASYCOOL/Rtn press:xxx. Check the return pressure.
4. Check to see if the values displayed are in the specified range and the system temperature is 20°C.
5. If the pressure is too high, following tools are required:
 - charge, a size 4, valve, female Aeroquip coupling
 - 5/8" and 3/4" flat wrenches
 - 5.1 Check the compressor has stopped and temperature stays at 20°C.
 - 5.2 Make sure the valve on the charge is closed. Use two wrenches to connect the adaptor to the #4 male Aeroquip coupling.
 - 5.3 Slowly opens the adaptor valve, vent all the helium in the system. Close the valve when required pressure obtained.
 - 5.4 Use the two wrenches to take the adaptor off.
6. If the pressure is too low, following tools are required:
 - charge, a size 4, valve, female Aeroquip coupling, 5/8" and 3/4" flat wrenches
 - Helium bottle
 - Relief valve
 - Gas line
 - 6.1 Stop the compressor.
 - 6.2 Install a charge, and open the valve slowly. Use two wrenches to connect the adaptor to the #4 male Aeroquip coupling. Close the valve.
 - 6.3 Connect the helium gas line to the helium bottle with 99.999% purity of helium, and the dew temperature of the helium is -50°C at 20.7bar.
 - 6.4 Clean the gas line thoroughly when connecting the gas line to the charge. Open the relief valve slightly; allow some gas to clean the gas line. At the same time, slightly open the valve on the charge, release some gas in the compressor, clear the remaining gas at the charge connector. Then both the gas line and the charge are cleaned. Connect these two parts without close the valve and relief, then close the charge valve. It is critical to remove all the impurities in the system.

- 6.5 Adjust the relief valve to equalize the pressure. See the specifications. Slightly open the valve on the charge. Fill in the helium to reach system equalization pressure.
- 6.6 Close the relieve valve on the charge and gas bottle.
- 6.7 Remove the gas line and charge. Keep the gas line clean and store it.

Install the Cold Head Cable(s)

1. Be sure the compressor is not running by pressing the OFF button.
2. Connect the cold head cable to the cold head cable receptacle on the compressor front panel. Connect the other end of the cable to the electrical receptacle on the cold head.

Diagnostic Interface Connector

Tool required: Small, flat blade screwdriver

A DB-9 connector is located on the front panel of the compressor for software update. A DB-25 connector is located on the front panel for remote control and to supply remote indication of the operating status of the compressor. See Figure 16.



NOTE

The DB-25 pin assignments are shown in the Appendix Section of this manual.

Prestart Check

1. Check that the cooling water lines are connected and that the supply is connected to the water in connection. Turn on the coolant and check the lines for leaks. Tighten the fittings if necessary.
 2. Check that all electric connections are made:
 - a. Power to the compressor
 - b. Cold head cable
 - c. Diagnostic interface cable (if used)
 3. Check that the electrical power supply is switched on.
- Check that the equalization pressure is as specified when the compressor is at room temperature 20° C.

OPERATION

Starting

Supply power to the compressor. Turn the knob of the main power switch on the front of the compressor to ON. Push the ON button on the compressor's front panel. The output voltage from the compressor to the cold head interface is 200 V3~.

CAUTION!

PREVENT EQUIPMENT DAMAGE.

After starting the system for the first time, to be certain that the water lines are properly connected, check that the outlet water temperature is warmer than the inlet water.

Stopping

Push the OFF button. The compressor and the cold head will stop. The output voltage of 200 V3~ from the compressor to the cold head interface stops.

Cold Head Only Run

For running the cold head only to perform a maintenance procedure, the cold head receptacle can be energized to 200 V3~ without running the compressor by:

- 1、 While the system is off, press DISPLAY, scrolling the display until "COLD HEAD RUN/YES-ON;NO-OFF" is shown.
- 2、 While "COLD HEAD RUN/YES-ON;NO-OFF" is displayed, press the ON button. Wait for about 10 seconds. If it doesn't return to the main interface "EASYCOOL/KDC6000V V4.x.x", the cold head only run is started. Check the cold head motor to make sure it is running.

The cold head will run until the OFF button is pressed or until 30 minutes of running has occurred.

Restarting after a Power Failure

When the power comes on, the microprocessor will determine if the last shutdown was due to a power outage. If the compressor power was interrupted by a power outage, the compressor and the cold head will restart automatically a few seconds after power is restored. If the compressor stops for other reasons, the LCD will show the specific problems.

NOTE

If the compressor stops due to a power excess, the compressor will restart automatically a few seconds after restart.

Automatic Restarting After a Helium High Temperature Shutdown Error

If a helium discharge high temperature shutdown error causes a shutdown of the system, the compressor will attempt to restart itself 5 times at 20 minute intervals before a reset signal must be provided to the compressor. A power outage will clear the shutdown error and reset the automatic restart counter.

System Status Display

Normal conditions: When all systems are operating normally, with no system errors, the following lines are displayed on the LCD in the order listed below by scrolling the display. Press the DISPLAY buttons (up and down arrows) to scroll the LCD. Scrolling past the bottom of the display will start back at the top and repeat. If the DISPLAY button is pressed and not pressed again after 10 seconds, the display will return to EASYCOOL/KDC6000V V4.x.x (Stop Status), or EASYCOOL/RunTime: xxx (Operating Status). If there' s no error, following items will be shown after pressing DISPLAY.

EASYCOOL/Ads time:xxx
 EASYCOOL/Phase seq:OK
 EASYCOOL/Helium temp:OK
 EASYCOOL/Water temp:OK
 EASYCOOL/Water flow:OK
 EASYCOOL/Return press:OK
 EASYCOOL/Rtn press:xxx
 EASYCOOL/Motor temp:OK
 Cold Head Run/YES-ON; NO-OFF

Error conditions: If a system error occurs that causes an alarm or shutdown condition, the monitor point as listed above will change from "OK" to "ERR" .

Any point that has not failed will continue to display OK if the operator manually scrolls the display.

If additional points fail before the operator resets the first error(s), the latest point to fail will change from "OK" to "ERR" and will be scrolled to the top for display. In this way, the operator will see the most recent fault displayed on the LCD and, by manually scrolling the display, can see other error conditions that lead up to the latest. If the operator does not press again in 3 seconds, the display will move the first error.

The "Ads time" displayed records the operating time of the absorber and remind the operator to replace the absorber in time. The records can be zero cleared.

Please contact the supplier for the absorber procurement and zero clearing.

Trouble Shooting

Error Conditions

An error condition will cause either a system alarm or a shutdown. The following table lists the alarm and the shutdown errors that are monitored. Overload trip of the Mains Power switch is not monitored or reported.

LCD Display Second Line	Type	Error	Indication
HHelium temp: ERR	Shutdown	High helium discharge temperature	Temperature > 93° C
Water temp: ERR	Alarm	High water supply temperature	Temperature > 38° C
Water flow: ERR	Alarm	Low water flow	Temperature > 46° C
Motor temp: ERR	Shutdown	High compressor motor winding temp (internal protector open)	Return Pressure > 9.7 bar
Phase Seq: ERR	Shutdown	Phase sequence or open fuse	Monitored by microprocessor
Return press: ERR	Shutdown	Loss of gas charge	Return pressure < 1.3 bar

If the compressor has been shut down by one of these interlocks, do not restart until the problem has been found and corrected. Refer to the Troubleshooting Guide to identify the problem.

In the event of a shutdown error, the compressor motor and cold head valve motor are turned off. The microprocessor will annunciate the error condition via signals at the System Diagnostics Connector and via the LCD Display. Signals are available on the 25-pin connector for output to an external device.

The Mains Power switch trips when steady-state current exceeds 1.2 x the front panel set point.

Clearing Error Conditions

When an error is corrected, the message(s) can be cleared from the display and the system diagnostic connector by any of the following procedures:

- Briefly contact the 5th and 24th pin of the diagnostic connector under remote control, or
- Press the RESET under local control, or
- Turn the Main Power switch to off, pause briefly, then turn back on

Restarting after an Error Conditions

When the shutdown is caused by helium discharge high-temperature, the compressor will be able to restart only after it has cooled enough for the thermistor to read a temperature below the cut-off point. After waiting for the compressor to cool, clear the error message then push the ON button to restart. Should the compressor fail to start, allow more cooling time. Repeat the restart procedure. Check cooling water temperature and flow. Compare with Specifications.

If the shutdown is due to a motor high temperature, the motor winding high temperature relay will automatically reset in approximately 30 minutes. To restart the compressor, clear the error message then push the ON button. If the compressor fails to start, allow more cooling time. Repeat the restart procedure.

If the shutdown is due to a motor high current, reset it by turning the knob completely to OFF, then clockwise to ON. The compressor and the cold head should start automatically after a few seconds.

NOTE

The motor temperature switch is indirectly monitored by the pressure sensor. When "Motor temp: ERR" is displayed, please check to see if the pressure sensor operates normally first.

Troubleshooting Guide

The Troubleshooting Guide that follows lists problems that can occur in the system and suggests causes and corrective actions.

Problem	Possible Cause	Corrective Action
System shutdown, second LCD reads Helium Temp-ERR	Low oil level or blocked oil circulation.	Try five times to restart the compressor. If it does not start, consult the supplier.
	Supply water temperature is too high.	Scroll LCD display. If Water Temp-ERR is indicated, supply water temperature is too high. Provide 5° C to 25° C cooling water.
	Water flow rate is inadequate.	Scroll LCD display. If Water Flow-ERR is indicated, the water flow rate is too low. Set water flow rate at 6 to 9 L/min.
	Water flow is reversed.	Refer to Compressor Checkout for correct installation of the water lines.
	Faulty gas thermistor or PCB.	Contact the supplier.
When press the start button on the compressor, it does not start up, cold head motor starts. System shutdown 3 seconds later, LCD reads Motor temp: ERR	Helium flow reverse (Compressor supply port connects to cold head return port)	Check all the gas lines.
	Compressor motor windings high temperature switch opens. Compressor motor windings have overheated.	Scroll LCD display. If Water temp: ERR or Water flow: ERR is indicated, cooling water is inadequate. Refer to Specifications. Consult the supplier if the problem persists. Allow about 30 minutes for the windings to cool enough for the switch to reset.
	Reversed phase or loss of phase.	Check mains power.
	Fuse(s) opened or poor power quality.	If power checks indicate utilities are within specifications, check fuses.
	Pressure transmitter malfunction	Press DISPLAY, check the "Rtn press: xxx" to see if it is reasonable and if it is close to the readings on pressure gauge. If it is not in a reasonable range, contact the supplier service.

System shutdown LCD reads Phase seq: ERR	Fuse(s) opened or poor power quality	If power checks indicate utilities are within specifications, check fuses.
System shutdown LCD Return press: ERR	Compressor has lost helium charge	Refer to Charging or Venting, Gas Clean-up and Leak Check in the Manual.
	Pressure transmitter malfunction	Contact the supplier.
Compressor and cold head motor do not start when the start switch on the compressor is pushed.	No electrical power.	Check that the power source is on and connected.
	Wrong voltage	Refer to the Power Supply Specification in the system manual.
	Main power phase sequence is wrong.	Interchange any two- (2) incoming power leads (except ground).
	Defective component in the power circuit.	Refer to Compressor Motor troubleshooting in this section.
	Tripped motor circuit protector on the front panel.	Reset the protector by turning the knob to OFF, then turn the knob clockwise to ON. Consult the supplier if the problem persists.
Compressor starts but shuts down later	Insufficient coolant for the compressor	Check the coolant flow and temperature. Refer to Specifications.
System starts but gas pressure is abnormally high or low.	Wrong equalization pressure.	Refer to Specifications and the section on Charging or Venting.
	Gas line couplings are not fully engaged.	Be sure that all gas couplings are fully engaged and torqued.
	Gas lines are connected wrong.	Reconnect. See the Installation section.
Cold head motor does not start when the compressor starts.	Cold head cable is not connected.	Stop the compressor. Connect the cable. Check connections at the cold head and at the compressor.
	Open circuit in the cold head cable.	Disconnect the cable. Check each conductor for continuity. Replace the cable if necessary.
	Fuse to protect the cold head motor is blown.	Contact the supplier to replace the fuse inside the electrical enclosure.

Cold head motor hums but does not start.	Open circuit in the cold head cable.	Disconnect the cable. Check each conductor for continuity. Replace the cable if necessary.
	Bad quality of input power	Check input power, compare with specifications.
	Fuse to protect the cold head motor is blown.	Contact the supplier to replace the fuse inside the electrical enclosure.
Cold head motor runs, but there is no cooldown.	Gas line couplings are not fully engaged.	Be sure that all gas couplings are fully engaged and torqued.
	Gas lines are connected wrong.	Reconnect. See the Installation section.
Intermittent operation.	Compressor is cycling on and off.	Check input power, coolant flow and temperature. Compare with Specifications.
Loss of refrigeration capacity.	Compressor malfunction.	Check input power, coolant flow and temperature, and equalization pressure. Compare with Specifications.
Compressor shuts down, LCD display is blank	Fuse to protect the cold head motor is blown.	Contact the supplier to replace the fuse inside the electrical enclosure.
	Malfunctioning control boards.	Contact the Supplier Service Center.
Compressor is unresponsive to remote or remote status signals do not match actual status (DB-25 diagnostic interface)	DB-25 pins are not connected to the peripheral configuration as specifications require.	Turn off the power. Connect the peripheral configuration based on the DB25 interface definition in specifications.
	PCB board malfunction	Contact the Supplier Service Center.

APPENDIX

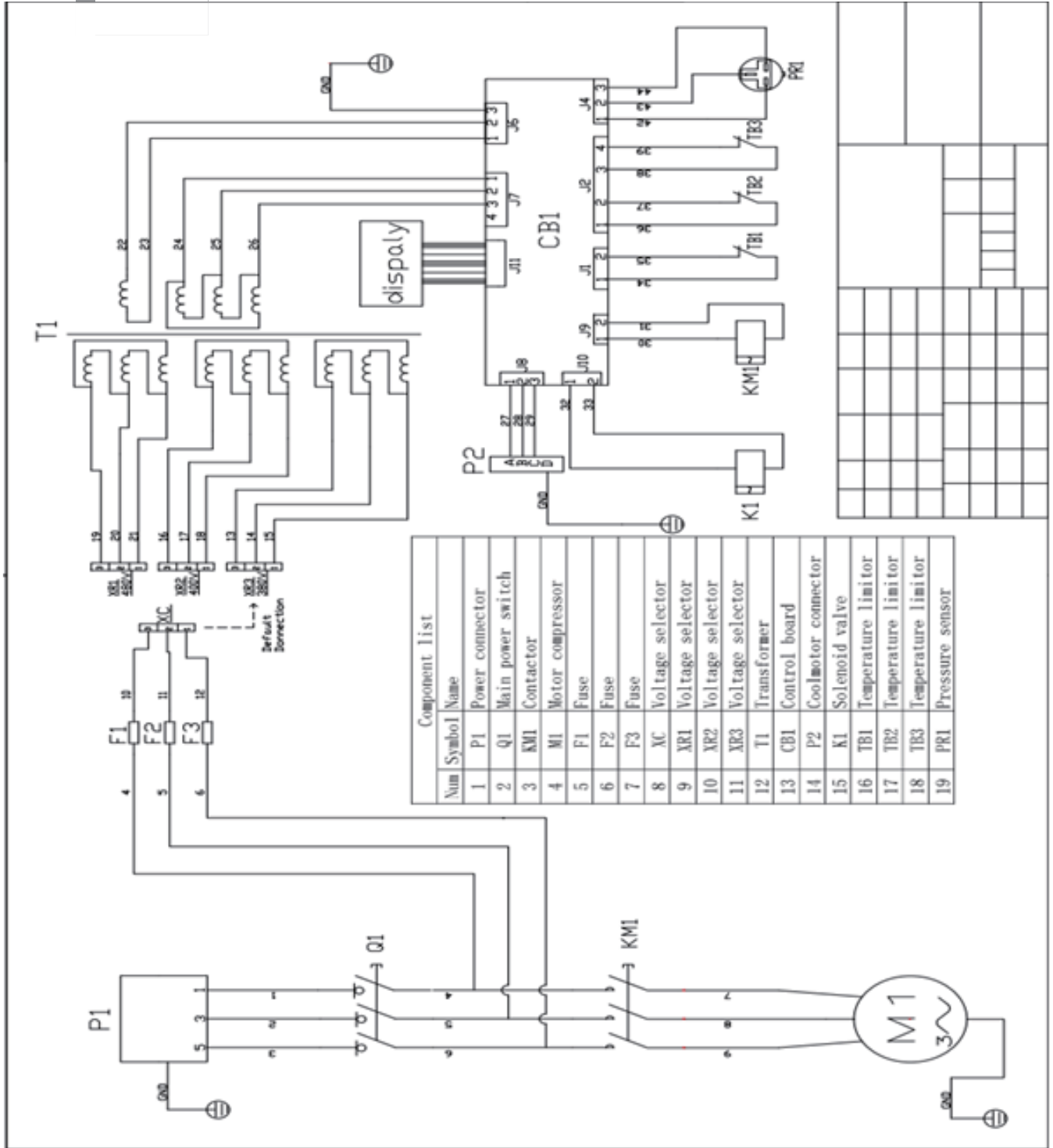

Appendix 1: KDC6000V compressor Wiring Diagram

Remote interface pin definition

Pin description		
PIN	Function	Description
4	Pause cold head motor	The cold head motor will be suspended when PIN4 is connected to DC24V and the compressor is in remote control mode.
5	Reset system errors	System errors will be reset when PIN5 is connected to DC24V and the compressor is in remote control mode.
6	Turn ON/OFF system	The compressor and cold head will be turned on when PIN6 is connected to DC24V and the compressor is in remote control mode.
7	Turn ON/OFF remote control	When PIN7 is connected to DC24V, the compressor will be in remote mode or in local mode.
12	INCOM	Input signal common.
13	OUTCOM	Output signal common.
1	Adsorber time error	The optical coupler will be activated when the adsorption time exceeds 35000 hours.
14	Run status	The optical coupler will be activated, when the compressor and cold head is running.
15	Motor temperature error	The optical coupler will be activated, when the compressor is running and return pressure > 9bar.
16	Solenoid valve status	The optical coupler will be activated, when the internal bypass solenoid valve is opened.
17	Phase sequence error	The optical coupler will be activated, when the phase sequence error or fuse error happens.
18	Water temperature error	The optical coupler will be activated, when the water temperature error happens.
19	Water flow error	The optical coupler will be activated, when the water flow error happens.
21	Helium temperature error	,The optical coupler will be activated , when the helium temperature error happens.
23	Return pressure error	The optical coupler will be activated, when the return pressure error happens.

Remote interface pin definition

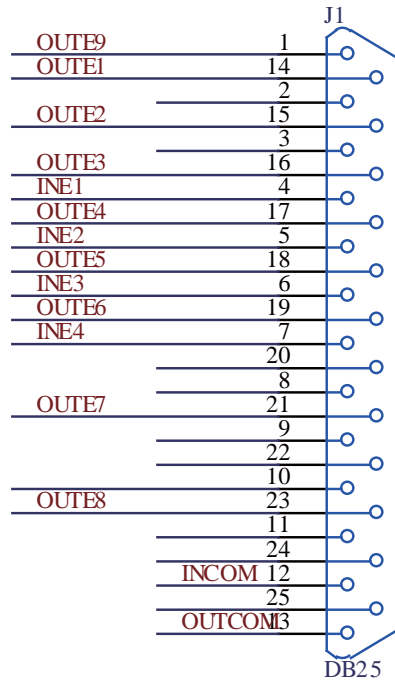

Internal schematic of remote interface

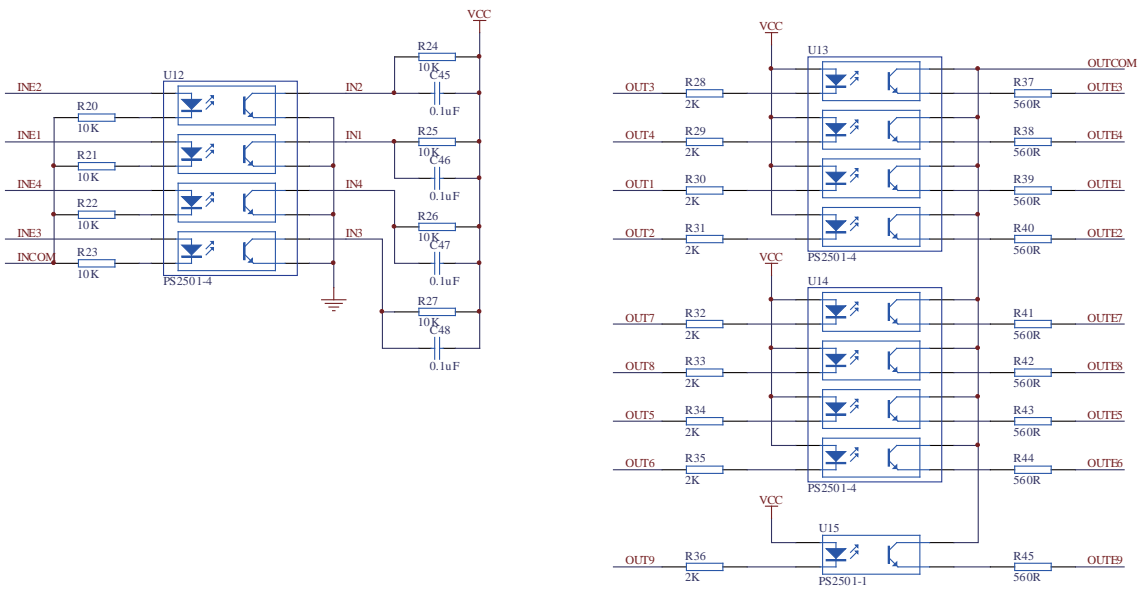

REVISION CONTROL

REV	Modify Content	Data
REV 1.0	First edition.	12-AUG-2014
REV 1.1	<ol style="list-style-type: none"> 1. On page 5, line 8, “psig” is changed to “psi”. 2. On page 10, line 20, (380/550V-GB13539) is changed to (BUSSMAN FNQ-R-2). 3. On page 11, line 13, “14 amperes” is changed to “16 amperes”. 4. On page 11, line 15, “< 1.0 bar” is changed to “< 1.3 bar”. 5. On page 11, line 17, “>35 °C ” is changed to “>38°C”. 6. On page 11, line 30 and line31, “psig” is changed to “psi”. 7. On page 12, line 17, “<14.5 psig” is changed to “<14.5 psi”. 8. On page 13, line 23, “13.5-14 bar” is changed to “16-16.5 bar”, “16.6-20.7 bar (240-300 psig)” is changed to “20-23 bar (290-334 psi)”. 9. On page 14, line 13, “(red)” is changed to “(yellow)”. 10. On page 18, section 2 is changed. 11. On page 18, section “Unpackaging and product inspection instructions” is deleted. 12. On page 26, line 15, “180mm” is changed to “200mm”. 13. On page 28, section 6.3, “and the temperature is -50°C at 20.7 bar” is changed to “and the dew temperature of the helium is -50°C at 20.7 bar”. 14. On page 32, line 3, “35°C” is changed to “38°C”. 15. On page 32, line 7, “<1.0bar” is changed to “<1.3bar”. 16. The appendix 2 on page 37 and page 38 is replaced. 	1-April-2018

EASYCOOL 易酷®

PRIDE Leading New Cryogenics Technologies

Tel: +86-25-68626268

Fax: +86-25-68626273

E-mail : cryosales@724pride.com

http : www.724pridecryogenics.com

Add: No.32 Changqing Road, Jiangning

PRIDE Development District, Nanjing 211106 P.R.C.